

## Measuring Procedure for Wear in Slewing Bearings for Crane Types GP and HH

### General

The slewing bearing is an essential part of the crane and must be well maintained. Over the years the slewing bearing will have some wear, and to be able to know if there is a need for changing the slewing bearing it is needed to keep a record of the wear.

**The initial measurements should be taken when the crane is installed at yard or within 2 months from crane installation.**

If the wear measurement shows wear, grease samples can be taken for analyze. See procedure on page 3.

### Measuring

Measurements should be taken regularly, every 6 months. When measurements are to be taken the ship shall have as little list/trim as possible.

### Reference points

On some cranes there are two machined surfaces in the front and rear of the crane bottom plate, see Fig. 1. These surfaces should be used when measuring the wear of the slewing bearing. If no such surfaces are provided two reference points must be marked on the crane bottom plate, see Fig. 2, to be used as reference point in future measuring.

The first time a measurement is to be taken four reference points must be marked on the foundation

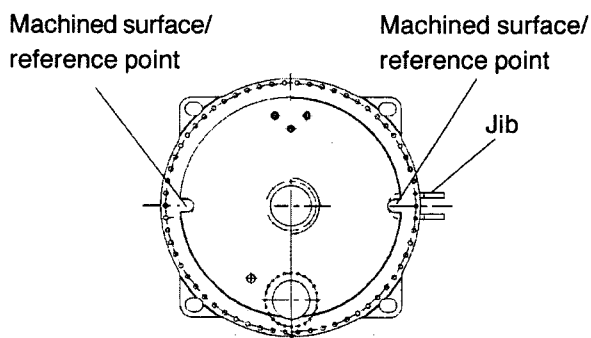

Fig. 1. Machined surface on crane bottom plate.

or lower face of slewing bearing (non rotating part). The reference points should be made on fore, starboard, aft and port side of the foundation/slewing bearing.

These reference points must be made in a way that ensures that they will last the lifetime of the bearing. The reference points shall always be used at any future measuring.

### Procedure

Two measurements shall be taken on four positions of the slewing bearing, if possible, with the jib pointing:

- forward to the ship
- starboard
- aft
- port side

See Fig. 3 or 4, depending on crane design.

It is important that the same position are used for all further measurements to be able to compare the measurements.

For maximum allowed wear, see table on page 4.

Enclosed table, on page 5, can be used to record the measurements.

**⚠ WARNING!**  
Do not enter the crane foundation during crane operation.  
Moving crane house and machine parts may suddenly cause bodily injury or death.

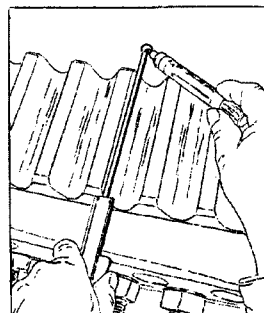

Fig. 2. Marking of reference points.

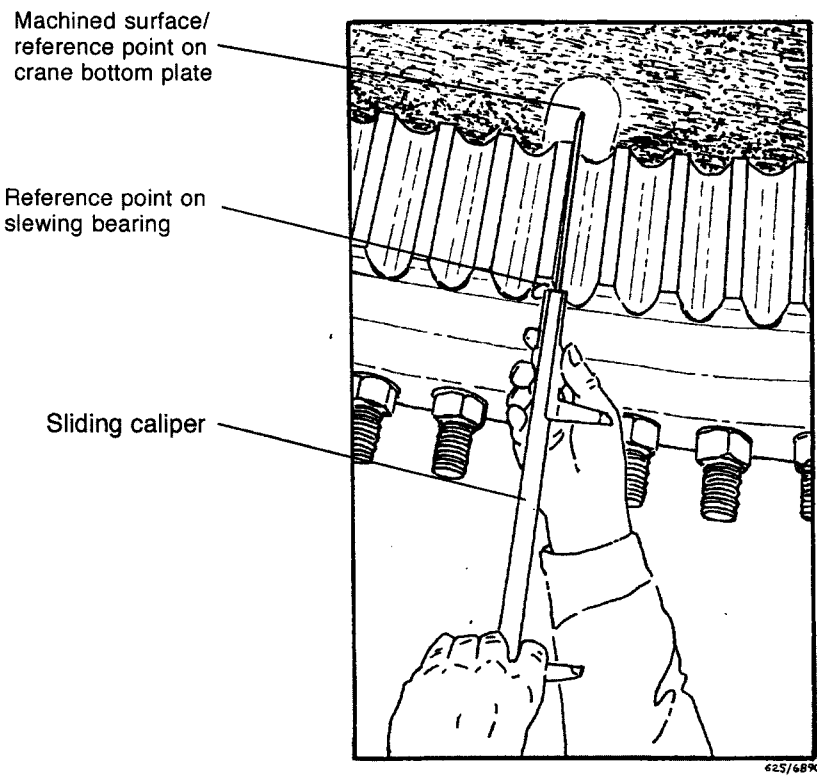
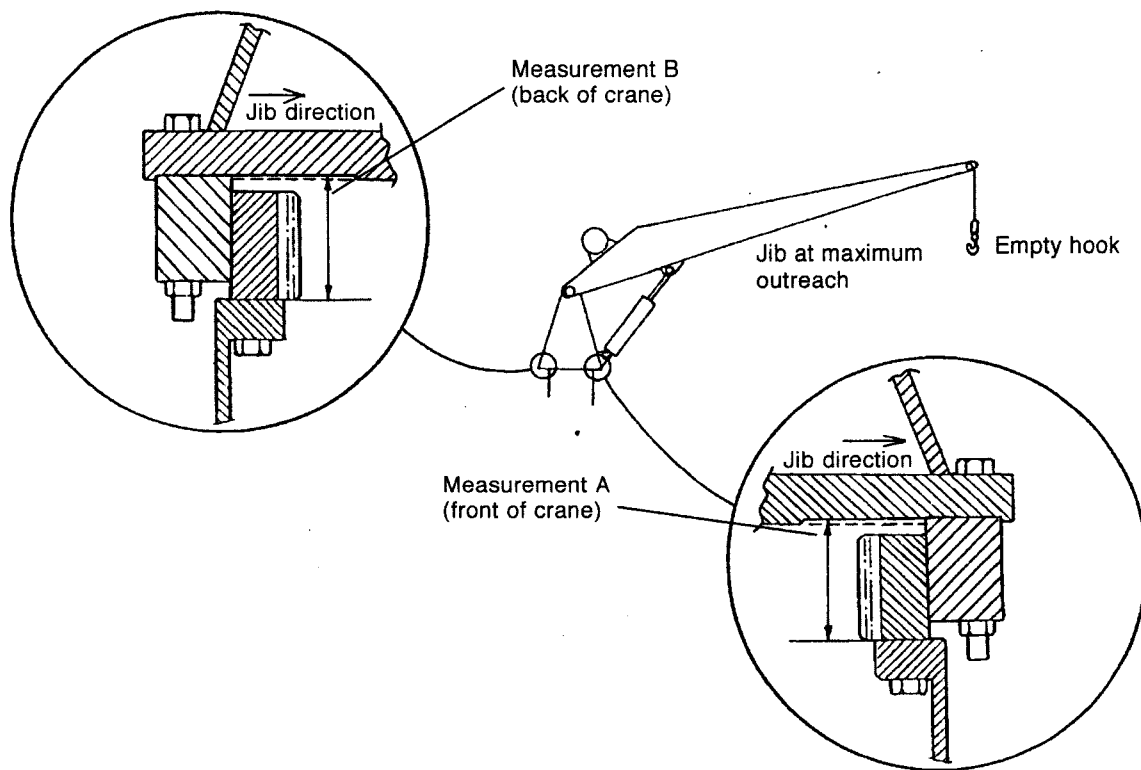

Fig. 3. Measuring wear on slewing bearing.

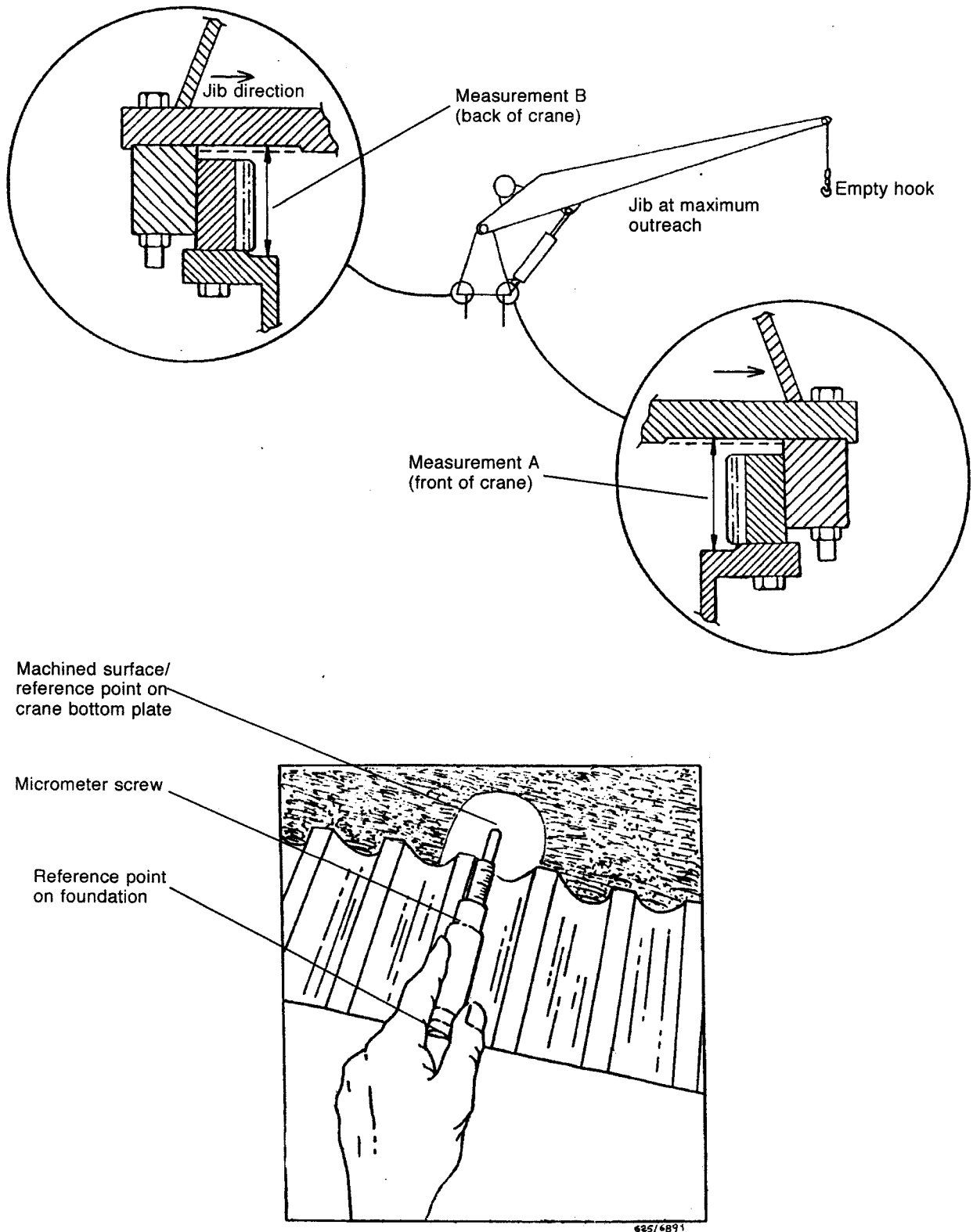

Fig. 4. Measuring wear on slewing bearing.

**Maximum allowed wear on slewing bearing**

Crane size	Allowed wear (mm)*
63	1.4
100	1.5
160	1.6
250	2.0
320	1.8
400	2.1
500	2.2
630	2.8
800	2.9

\* Allowed wear is the maximum difference between initial measurement and actual measurement, see table on page 5.

For crane size, see Technical Data in section 2 of the instruction manual:

Type of crane : GP 100-xxxx  
HH 400-xxxx

**If the measured wear is bigger than the allowed wear contact MacGREGOR (SWE) AB, Service Division.**

**Procedure for grease sampling**

Following information is necessary in order to give a correct statement and allow further advice:

1. Used grease (manufacturer and type).
2. Lubrication intervals.
3. Running hours.
4. Information where the samples are taken.

The correct procedure for grease sampling is very important.

**Procedure**

Proceed as follows:

- The grease sample can be taken either at the inner or outer seal of the bearing.

- One sample should be taken in the area under jib and one sample 180° in opposite direction.
- Clean the outer or inner seal close to the next grease nipple. When cleaning the area of the seal, prevent the cleaner from contacting the seals or from entering the raceway's system.
- Push new grease into the grease nipples / bearing without rotation and collect the **first** used grease which will come out at the seal.

**Attention:** Do not take fresh grease for analyzing!  
The required quantity of grease for analyzing is approx. 2 cm<sup>3</sup>.

**Measuring of wear on slewing bearing**

Vessel name:

Crane No./Mfg. No.:

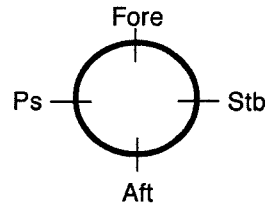

		Initial Measurement (accuracy 0.1 mm)		Allowed wear (see table on page 4)
Date	Jib direction	A1 (front of crane)	B1 (back of crane)	
	Fore	mm	mm	mm
	Stb	mm	mm	mm
	Aft	mm	mm	mm
	Ps	mm	mm	mm

		Actual measurement (accuracy 0.1 mm)		Measured wear	
Date	Jib direction	A (front of crane)	B (back of crane)	A - A1	B1 - B
	Fore	mm	mm	mm	mm
	Stb	mm	mm	mm	mm
	Aft	mm	mm	mm	mm
	Ps	mm	mm	mm	mm

		Actual measurement (accuracy 0.1 mm)		Measured wear	
Date	Jib direction	A (front of crane)	B (back of crane)	A - A1	B1 - B
	Fore	mm	mm	mm	mm
	Stb	mm	mm	mm	mm
	Aft	mm	mm	mm	mm
	Ps	mm	mm	mm	mm

		Actual measurement (accuracy 0.1 mm)		Measured wear	
Date	Jib direction	A (front of crane)	B (back of crane)	A - A1	B1 - B
	Fore	mm	mm	mm	mm
	Stb	mm	mm	mm	mm
	Aft	mm	mm	mm	mm
	Ps	mm	mm	mm	mm

THIS PAGE IS INTENTIONALLY LEFT BLANK